



FUJII ELECTRIC

SPLIT TYPE ROOM AIR CONDITIONER WALL MOUNTED type

SERVICE MANUAL

Models	Indoor unit	Outdoor unit
	RSW-14CB	ROW-14CB
	RSW-14HB	ROW-14HC

C O N T E N T S

SPECIFICATIONS	1
DIMENSIONS	2
REFRIGERANT SYSTEM DIAGRAM	3
CIRCUIT DIAGRAM	4
INDOOR PRINTED CIRCUIT BOARD CIRCUIT DIAGRAM	6
DISASSEMBLY ILLUSTRATION	7
PARTS LIST	13



Большая библиотека технической документации

<https://splitsystema48.ru/instrukcii-po-ekspluatácii-kondicionerov.html>

каталоги, инструкции, сервисные мануалы, схемы.

S P E C I F I C A T I O N S

INDOOR UNIT		RSW-14CB	RSW-14HB
OUTDOOR UNIT		ROW-14CB	ROW-14HC
COOLING CAPACITY	(kW)	3.85 - 4.00	3.85 - 4.00
HEATING CAPACITY	(kW)	—	4.65 - 4.80

ELECTRICAL DATA

POWER SOURCE	(V)	220 - 240	
FREQUENCY	(Hz)	50	
RUNNING CURRENT	(A)	COOLING	7.2 - 7.5
		HEATING	—
INPUT WATTS	(kW)	COOLING	1.48 - 1.55
		HEATING	—
EER	(kW/kW)	COOLING	2.60 - 2.53
		HEATING	—
MOISTURE REMOVAL	(ℓ /hr)	1.6	1.6
AIR CIRCULATION-Hi	(m³/hr)	540	540

COMPRESSOR

TYPE	Hermetic type, Permanent split condenser, 2 pole, Single phase, Induction motor
CODE	C-R140H5W

FAN MOTOR

		INDOOR UNIT		OUTDOOR UNIT	
MODEL		RSW-14CB	RSW-14HB	ROW-14CB	ROW-14HC
TYPE		MFA-17AT		MFB-14VTT	
POWER SOURCE	(V)	220 - 240		220 - 240	
FAN SPEED	HI-SPEED (r.p.m.)	1,240		750	
	MED-SPEED (r.p.m.)	1,160			
	LO-SPEED (r.p.m.)	1,080			

DIMENSIONS

HEIGHT x WIDTH x DEPTH	(mm)	285 x 900 x 172	530 x 750 x 250
------------------------	------	-----------------	-----------------

WEIGHT

GROSS / NET	(kg)	13 / 10	38 / 36	39 / 37
-------------	------	---------	---------	---------

REFRIGERANT CHARGE (R-22)

PIPE LENGTH		16 ft (5 m)	23 ft (7 m)	33 ft (10 m)
FULL CHARGE AMOUNT	RSW-14CB	38.4 oz (1,090 g)	39.9 oz (1,130 g)	42.0 oz (1,190 g)
	RSW-14HB	38.8 oz (1,100 g)	40.2 oz (1,140 g)	42.3 oz (1,200 g)

Note : Between 5 m and 10 m, when using a connection pipe other than that in the table, charge additional refrigerant with 0.7 oz (20 g) / 3.3 ft (1 m) for RSW-14CB, RSW-14HB as the criteria.

DIMENSIONS

INDOOR UNIT

Models : RSW-14CB, RSW-14HB

(unit : mm)

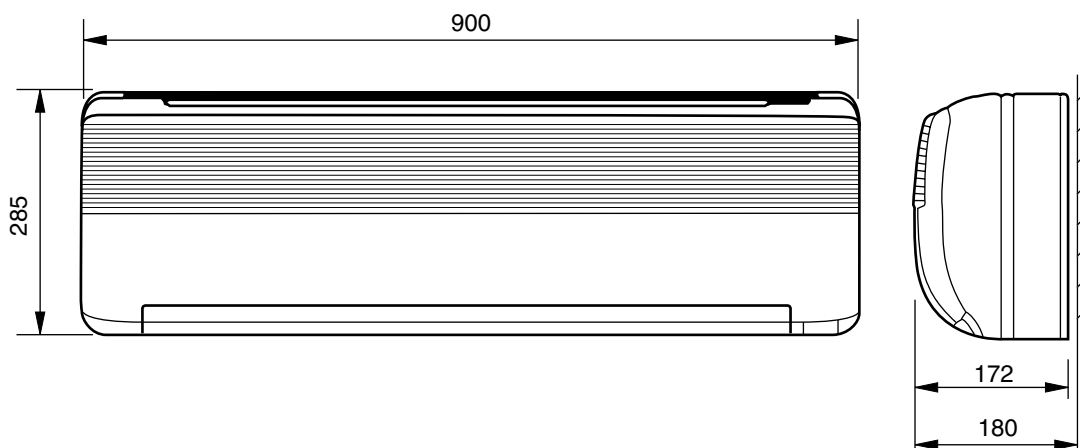

OUTDOOR UNIT

Models : ROW-14CB, ROW-14HC

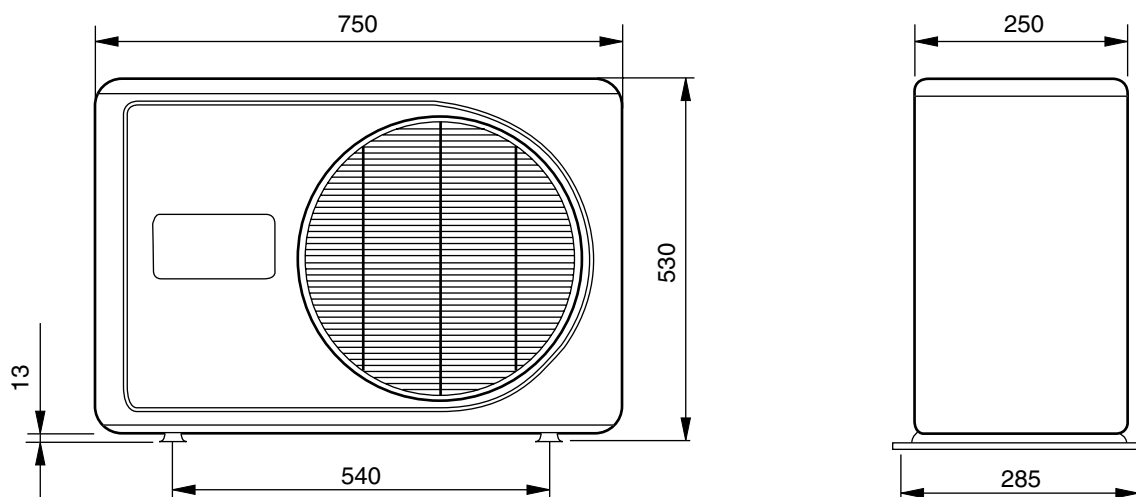

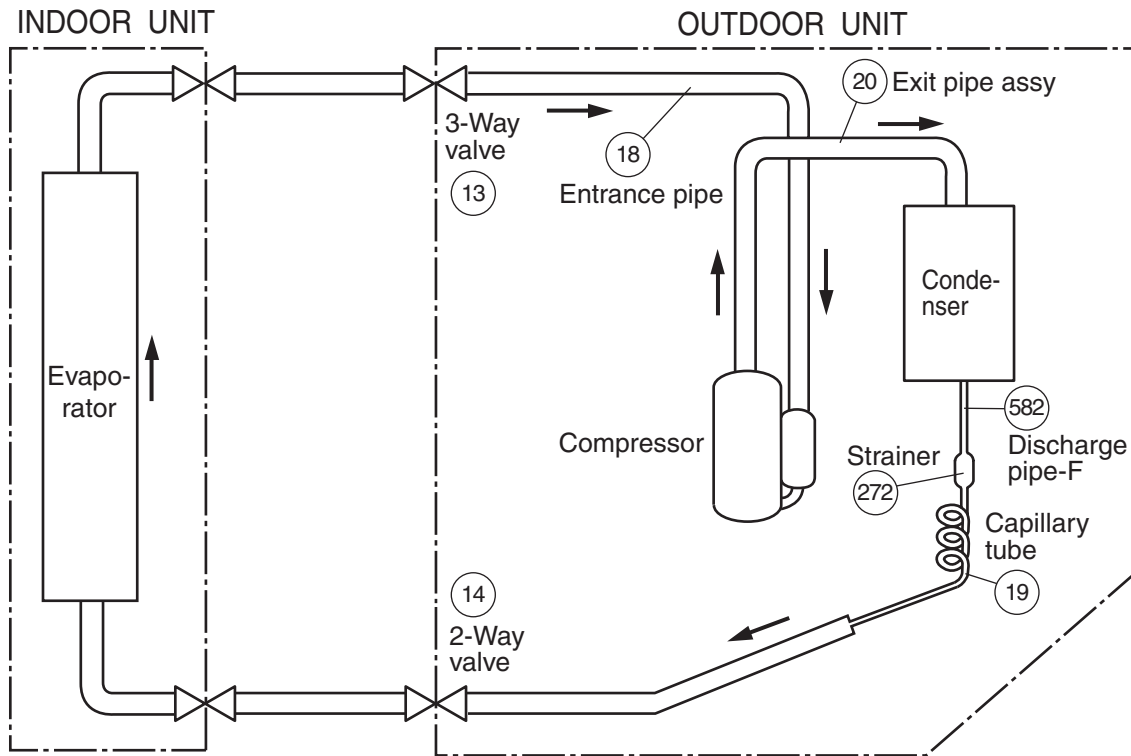

REFRIGERANT SYSTEM DIAGRAM

Models : RSW-14CB / ROW-14CB

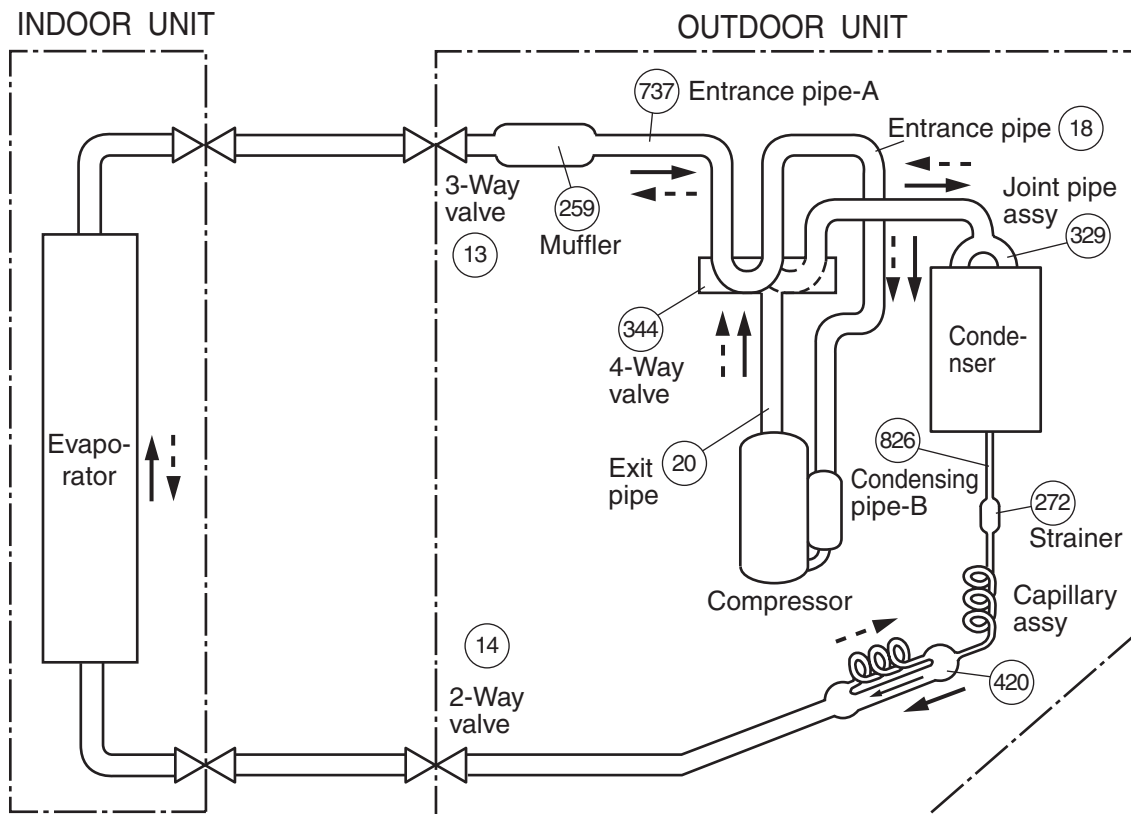

Models : RSW-14HB / ROW-14HC



-  Cooling
-  Heating
-  Flare coupling

Circled figures show the Ref. No. in the parts list on page 14.

CIRCUIT DIAGRAM

Models : RSW-14CB / ROW-14CB

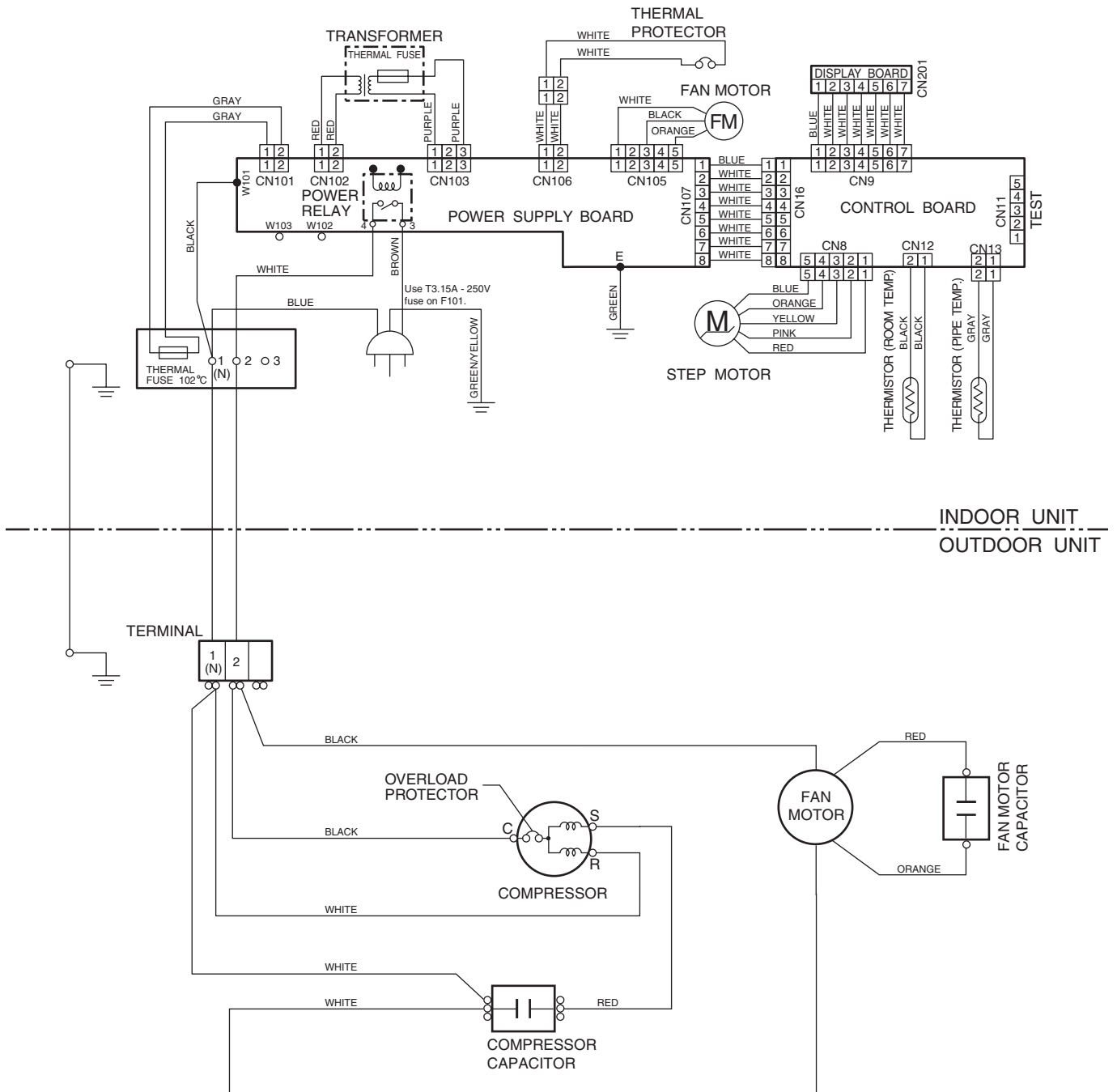

Models : RSW-14HB / ROW-14HC

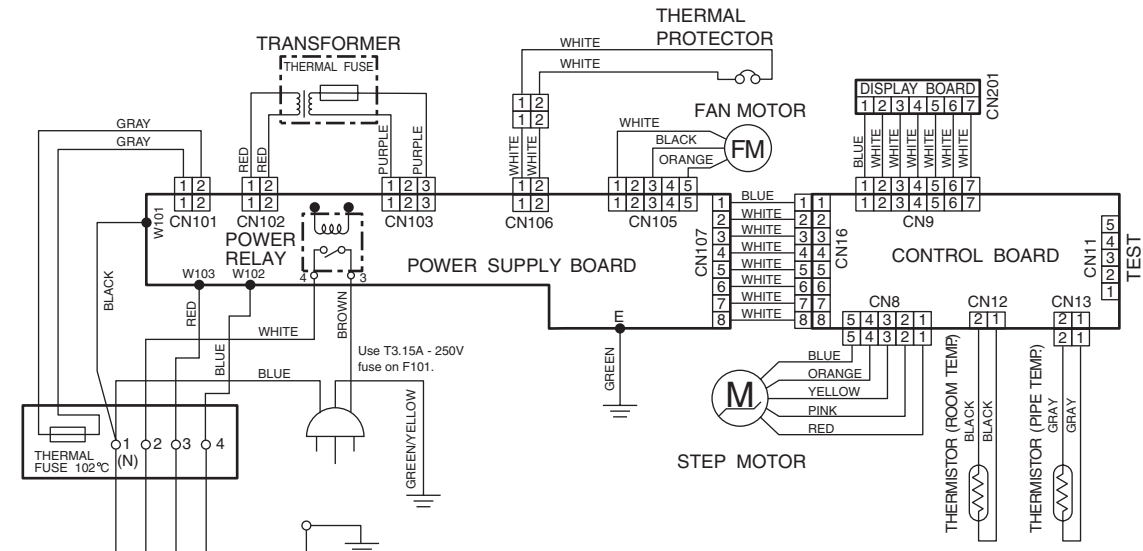

INDOOR UNIT

OUTDOOR UNIT

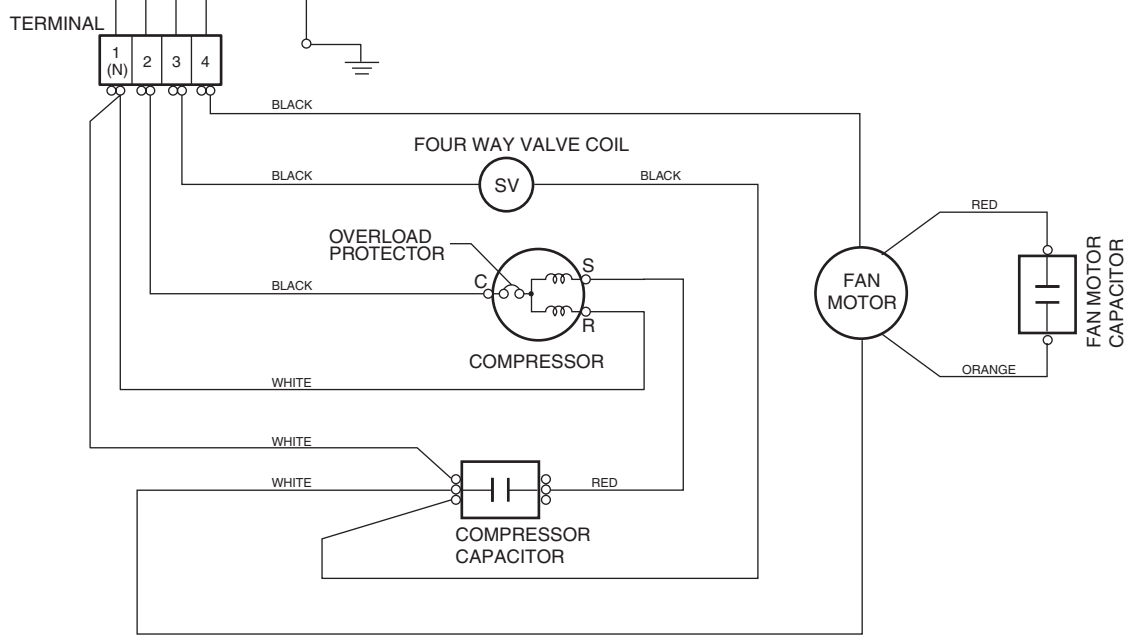

INDOOR PRINTED CIRCUIT BOARD CIRCUIT DIAGRAM

Model : RSW-14CB

CONTROLLER PCB ASSEMBLY (MAIN PCB) EZ-095GWSE-C (F)

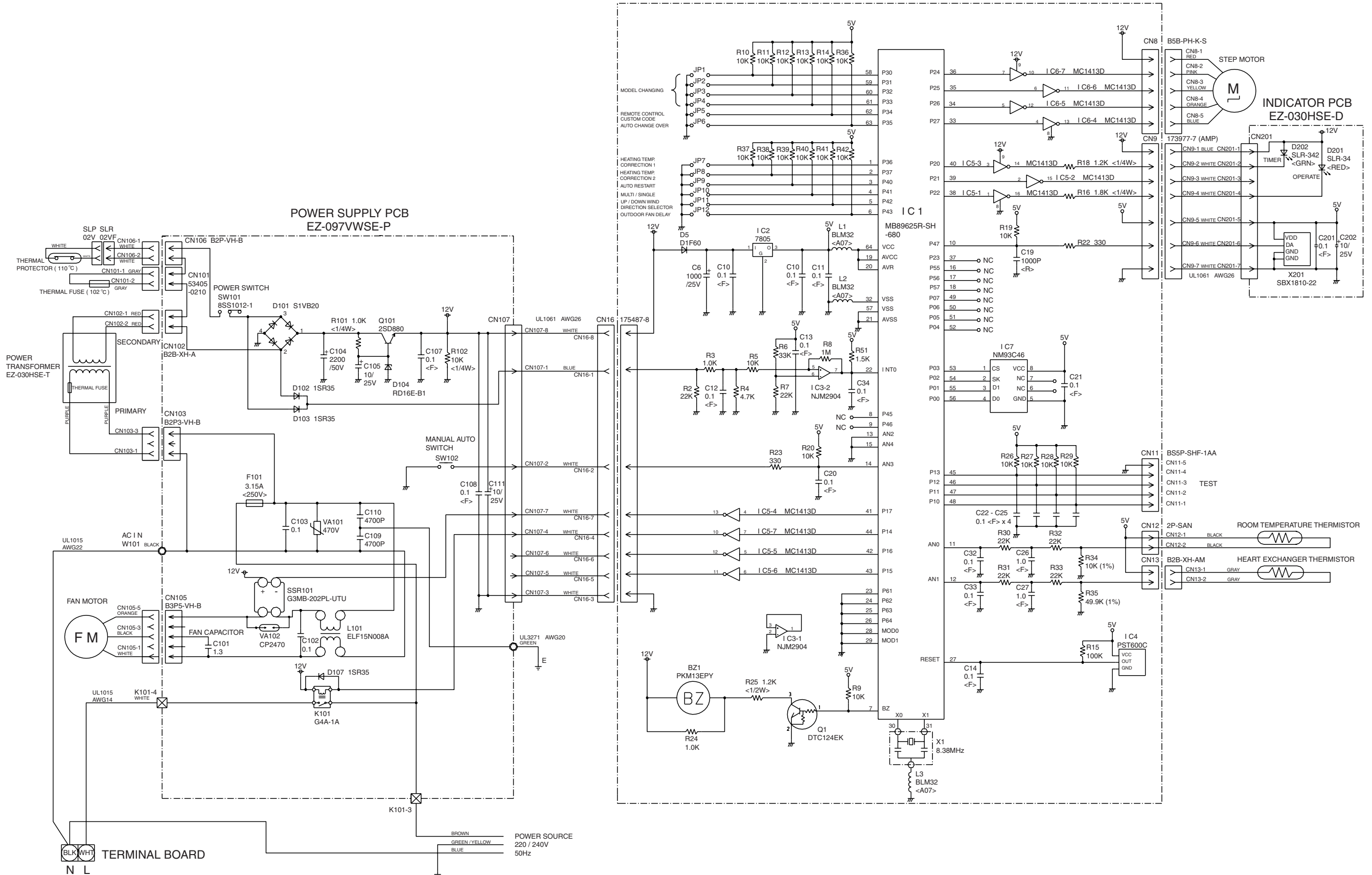

Model : RSW-14HB

CONTROLLER PCB ASSEMBLY (MAIN PCB)
EZ-095RHSE-C (F)

POWER SUPPLY PCB
EZ-097THSE-P

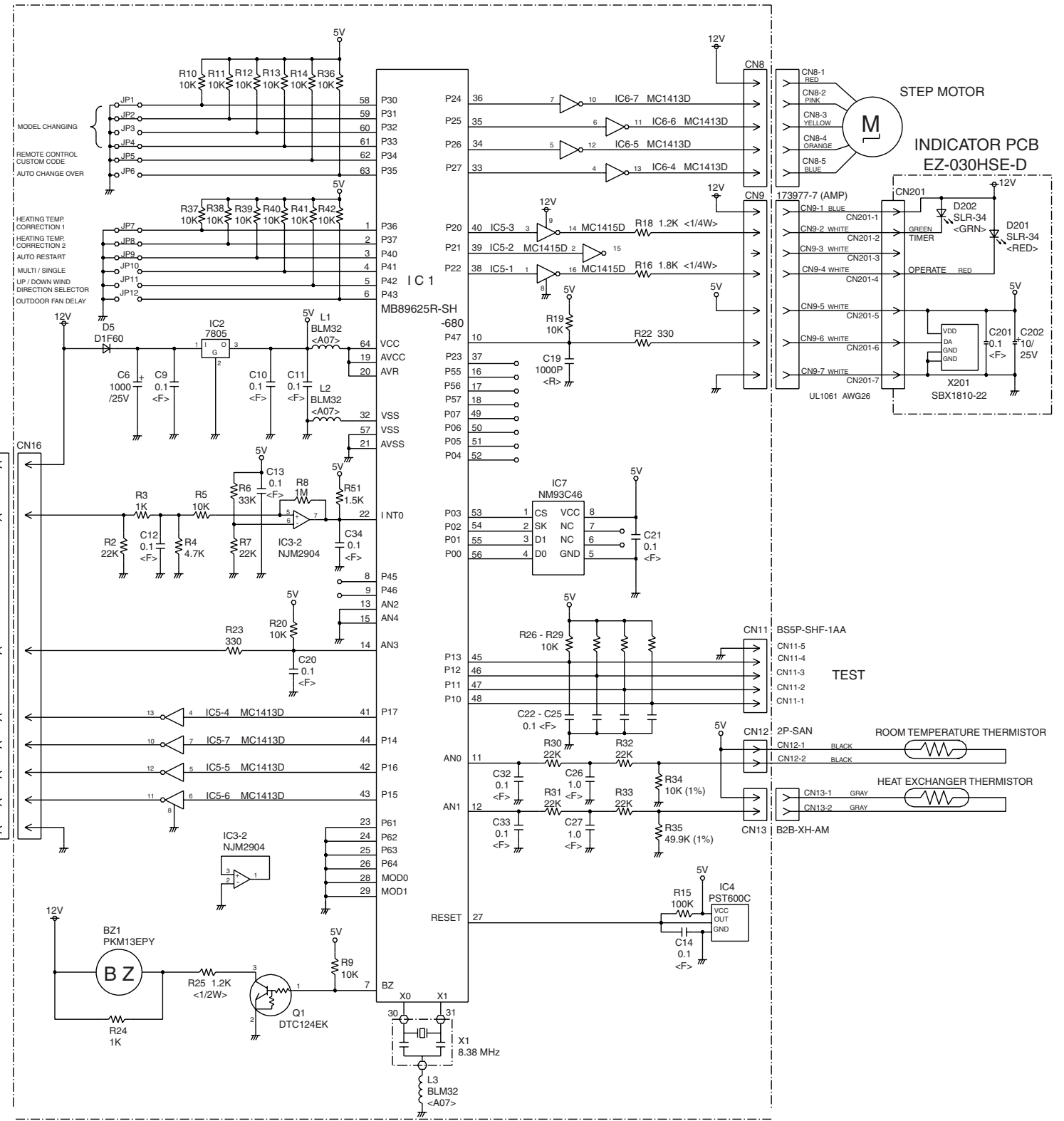
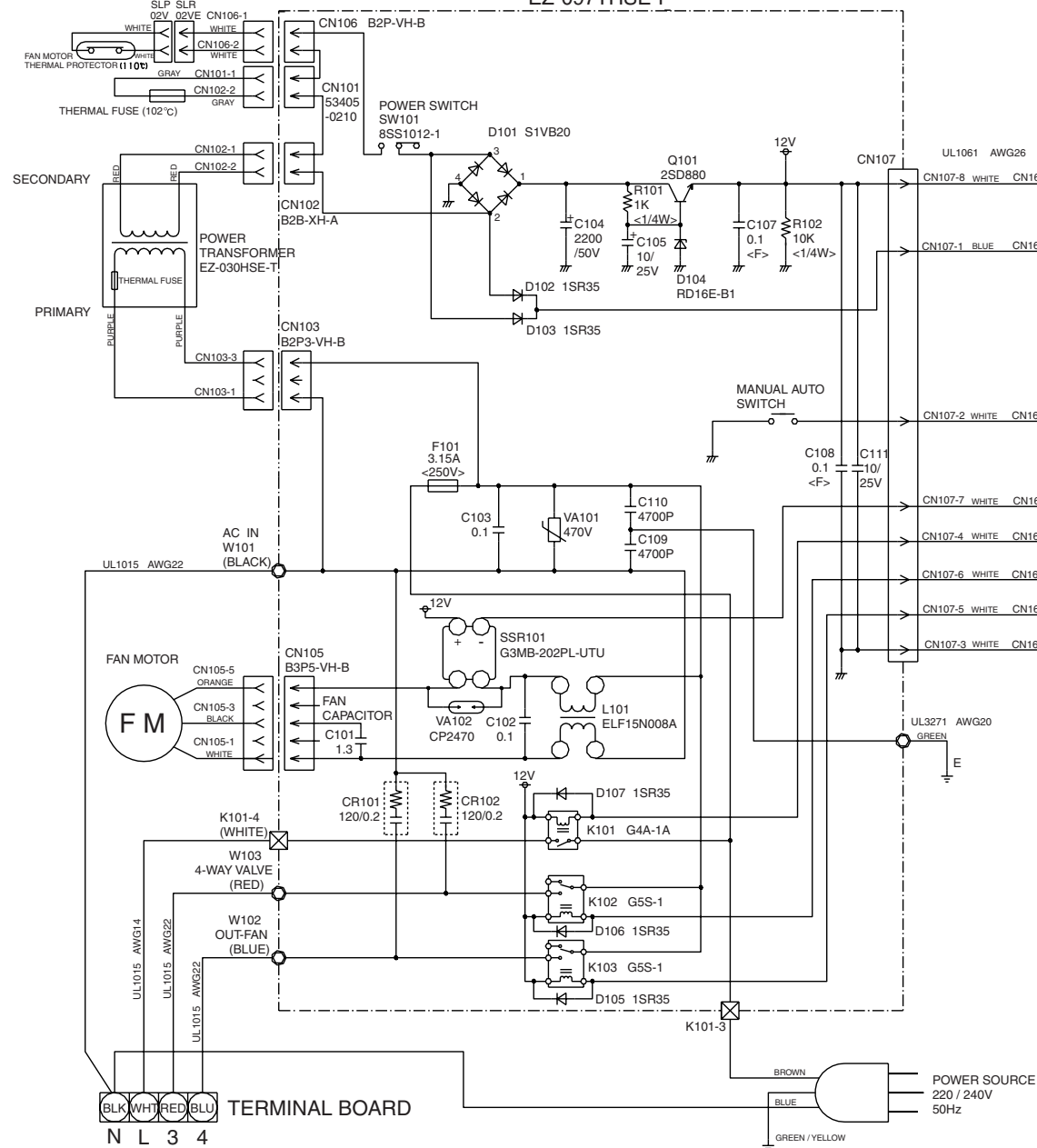

DISASSEMBLY ILLUSTRATION

Models : RSW-14CB
RSW-14HB

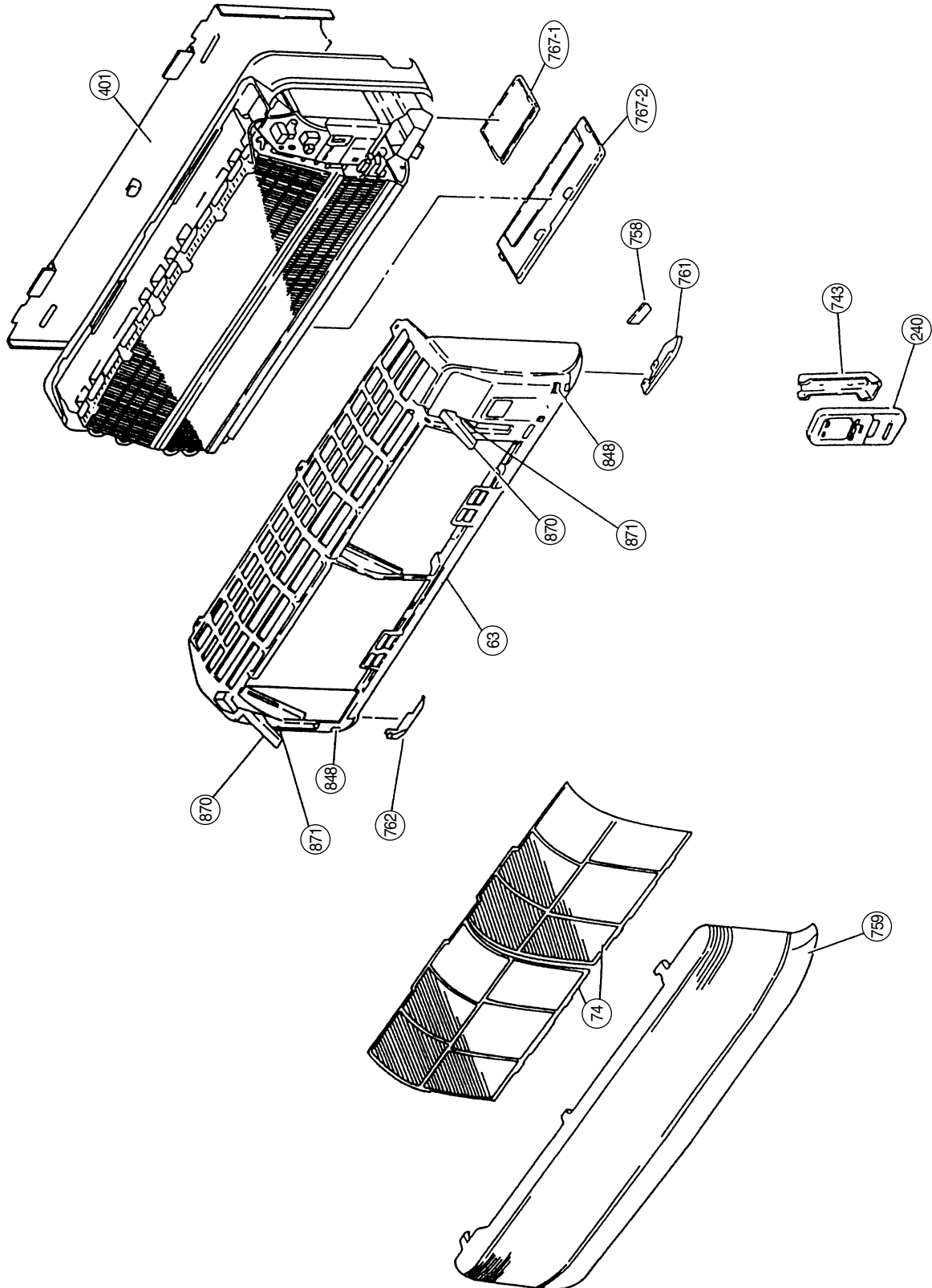

Models : ROW-14CB
ROW-14HC

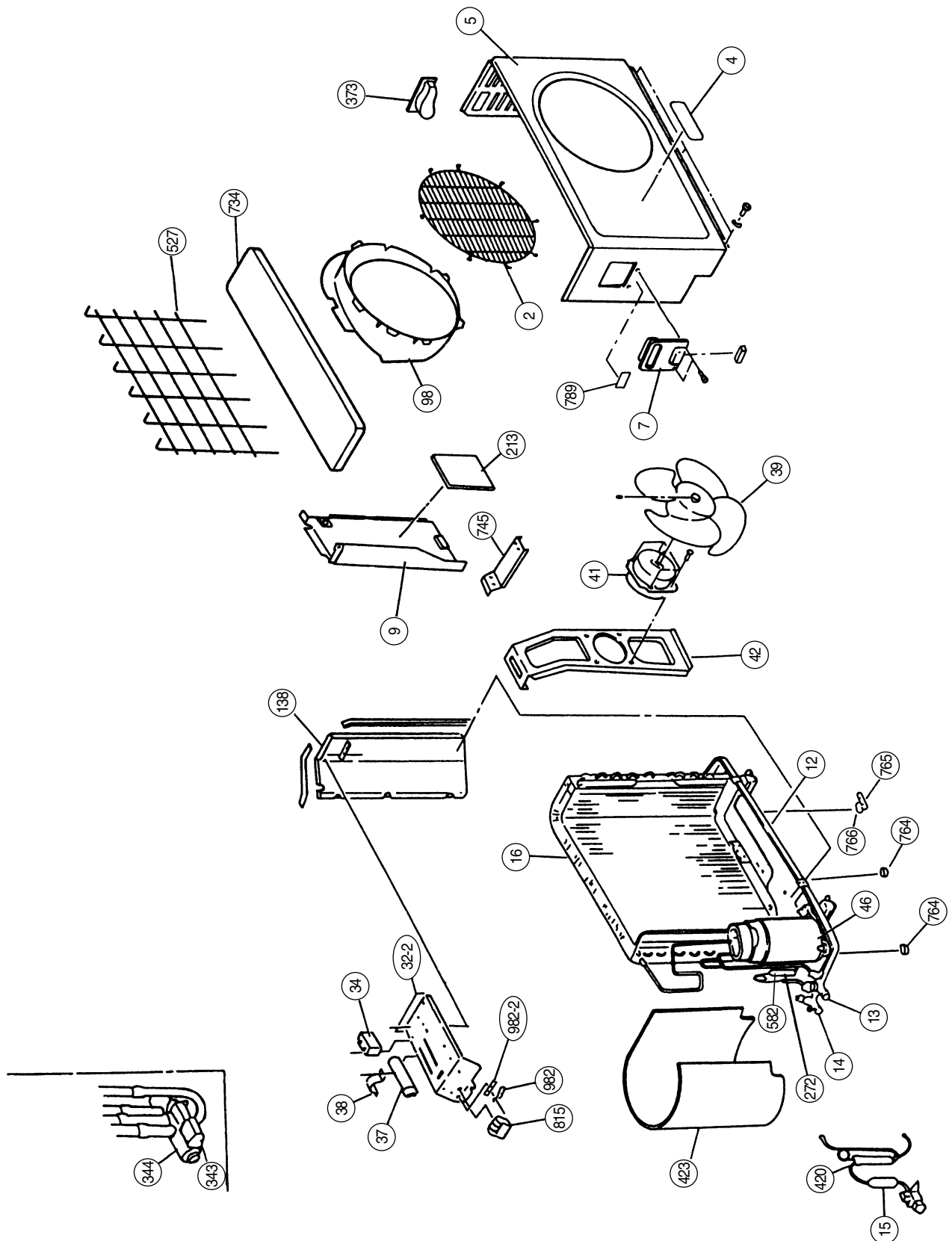

Models : ROW-14CB
ROW-14HC

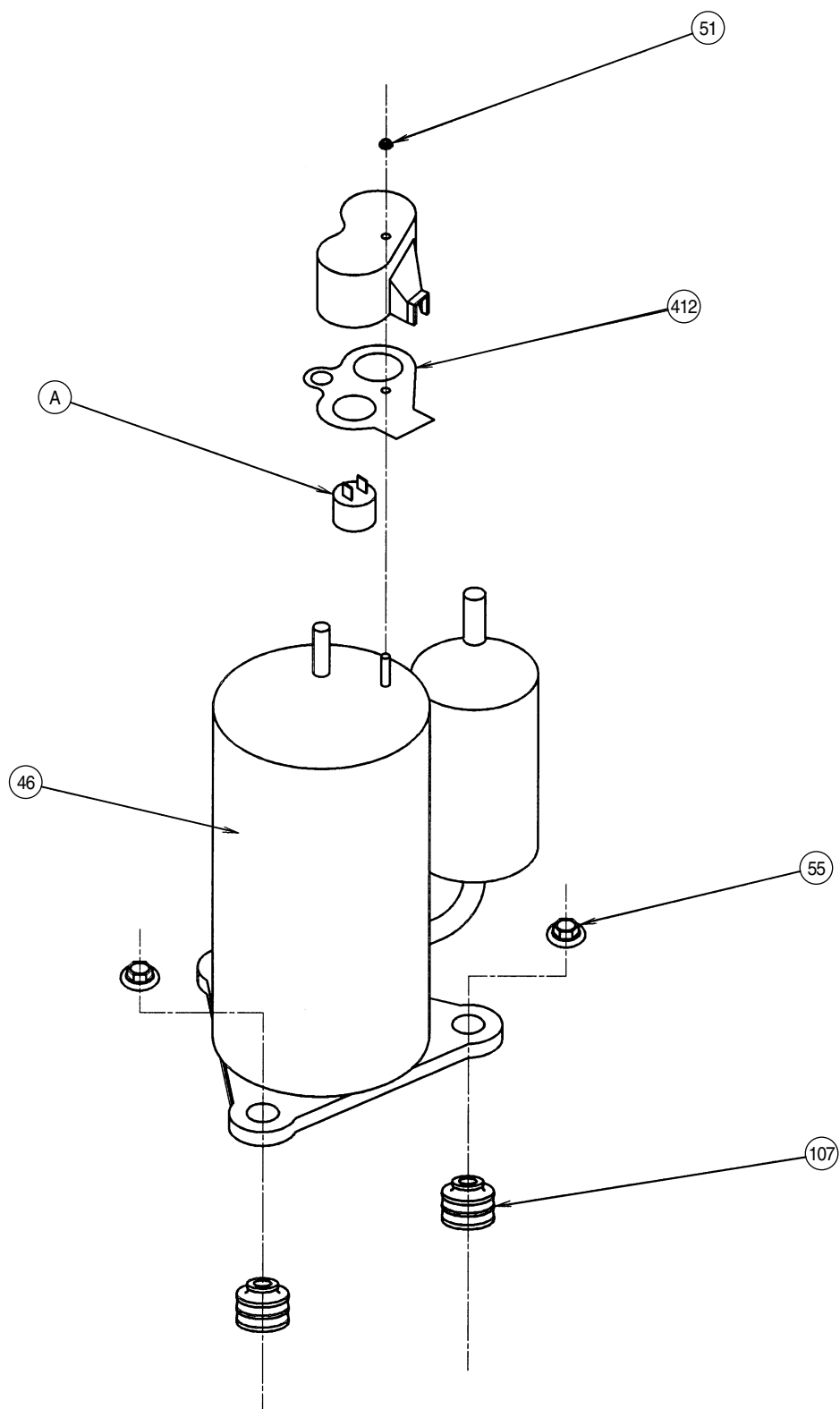

Model : ROW-14CB

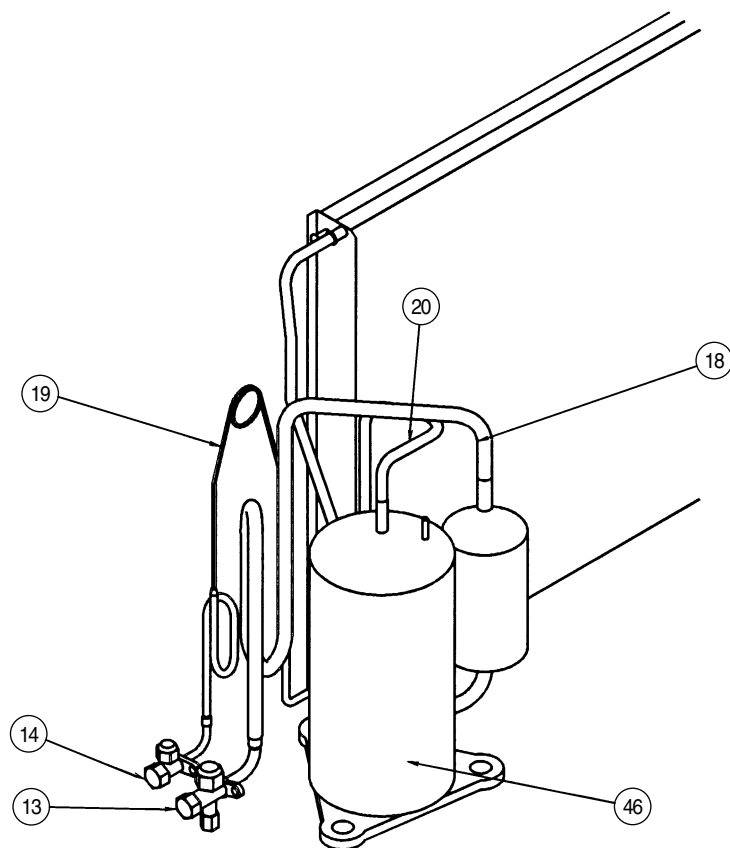

Model : ROW-14HC

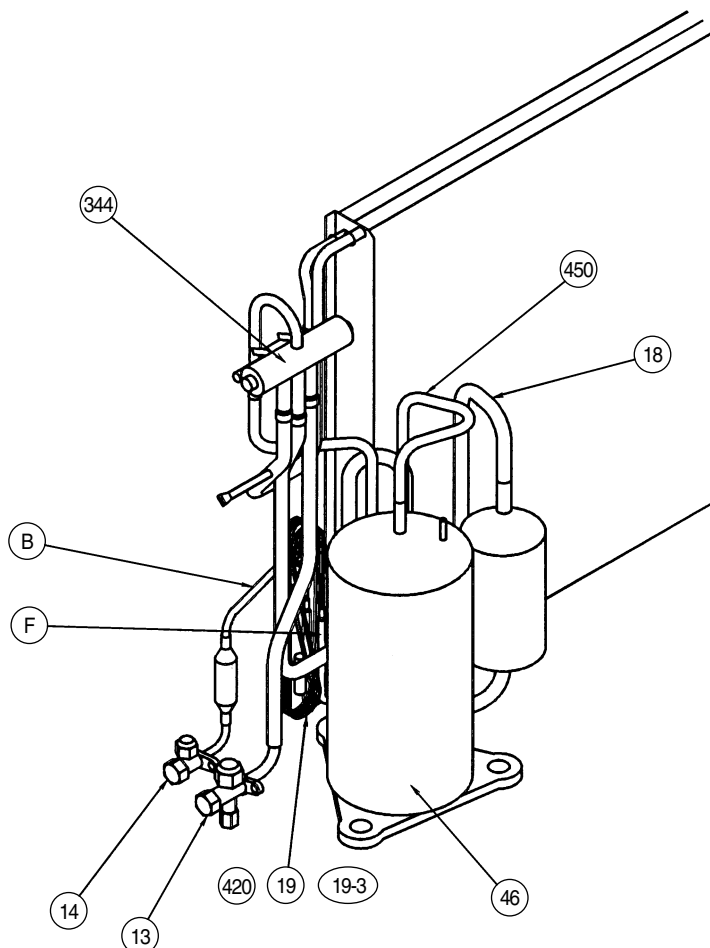

PARTS LIST

When you order parts, please make a photocopy of this page and fill the number of the parts in the "Order" column.

INDOOR UNIT

Ref. No.	Description	Part No.		Ord. Q'ty	Ref. No.	Description	Part No.		Ord. Q'ty
		RSW-14CB	RSW-14HB				RSW-14CB	RSW-14HB	
28	Blower Cover	9304111016	9304111016		406	Louver-L Assy	9354644014	9354644014	
63	Front Panel Assy "FUJI ELECTRIC"	9354229174	9354229174		407	Louver-R Assy	9354643017	9354643017	
65	Flow Control Panel	9354646094	9354646094		425	Earth Terminal	9357852003	9357852003	
74	Filter	9304097013	9304097013		652-1	Thermistor Holder Pipe	313714262805	313714262805	
108	Base	9304107033	9304107033		736	Operation Panel	9354230002	9354230002	
109	Casing	9304108016	9304108016		743	Remote Control Unit Holder Case	9305642014	9305642014	
122	Shaft Holder-B Assy	9304470007	9304470007		758	Decoration Plate-A	9354223011	9354223011	
127	Drain Hose Assy	9368754013	9368754013		759	Intake Grille-A "FUJI ELECTRIC"	9355595063	9355595063	
146	Evaporator Assy	9304079002	9304079002		761	Side Cover-R	9303518076	9303518076	
151	Control Box	9304029001	9304029001		762	Side Cover-L	9303520147	9303520147	
158	Joint Pipe Assy	9304286011	9304286011		764	Drain Cap Assy	9304150008	9304150008	
164	Fan Motor Assy-IN	9354513044	9354513044		767-1	Bottom Cover-A	9303536056	9303536056	
169	Crossflow Fan Assy	9306327002	9306327002		767-2	Bottom Cover-B	9303537053	9303537053	
178	Motor Cushion-G	9304669005	9304669005		780	Key Top (Slide Switch)	9303526002	9303526002	
184-1	Thermistor Spring-A	313728262708	313728262708		815	Terminal-2P	9701955022	—	
185	Wire Clamp	9356959000	9356959000		815	Terminal-4P	—	9701955039	
188	Power Cord Assy	8702595029	8702595029		848	Catcher	9306545000	9306545000	
233	Power Transformer	9701803026	9701803026		870	Arm	9303525005	9303525005	
235	Thermistor Assy-Pipe	9702325015	9702325015		871	Arm Spring	9304377009	9304377009	
236	Controller PCB Assy	9704341013	9704341020		872	Indicator Case	9303631003	9303631003	
240	Remote Control Unit	9356765076	9356765069		874	Control Box Cover	9304094005	9304094005	
251	Hose Clamp (Drain Hose)	9304077008	9304077008		875	Power Supply PCB Assy	9702451073	9702451066	
268	Motor Cover-B	9304231004	9304231004		876	Step Motor	9304535003	9304535003	
281	Clamp Metal (Pipe)	9304242000	9304242000		963	Fan Guard	9356881011	9356881011	
283	Bushing-A	9303529010	9303529010		977	Louver Clip, Plastic	9356880014	9356880014	
345	Filter Guide	9304110019	9304110019		978	Wire Bracket-L	9356878011	9356878011	
385	Indicator PCB Assy	9701119219	9701119219		979	Wire Bracket-R	9356877014	9356877014	
401	Wall Hook Bracket	9304093008	9304093008		983	Thermistor Protect Cover	9356882001	9356882001	







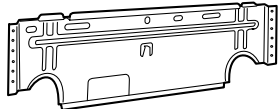
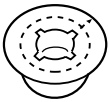

When you order parts, please make a photocopy of this page and fill the number of the parts in the "Order" column.

OUTDOOR UNIT

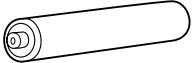

Ref. No.	Description	Part No.		Ord. Q'ty	Ref. No.	Description	Part No.		Ord. Q'ty
		ROW-14CB	ROW-14HC				ROW-14CB	ROW-14HC	
2	Fan Cover	9304109006	9304109006		138	Separate Wall	9303729014	9303729014	
4	Emblem-Rear "FUJI ELECTRIC"	9361328006	9361328006		213	Noise Insulation-B	313584258008	313584258008	
5	Cabinet, Painted	9302936017	9302936017		259	Muffler	—	313505083900	
7	Connector Cover (Cabinet)	9357970004	9357970004		272	Strainer	9357309002	9301340006	
9	Cabinet Rear Panel	9303744017	9303744017		329	Coupling Pipe Assy	—	9352375002	
12	Base Assy, Panel	9354493070	9354493070		343	Solenoid Coil	—	9704061034	
13	3-Way Valve Assy	9364616001	9364616001		344	4-Way Valve	—	9307556012	
14	2-Way Valve	9364615004	9364615004		373	Grip	313166178700	313166178700	
16	Condenser Assy	9365671009	9365670002		412	Terminal Gasket (Comp.)	9364725000	9364725000	
18	Entrance Pipe	9364832005	9364827001		420	Capillary Assy	—	9364828008	
19	Capillary Tube	9364835006	—		423	Noise Insulation-F	9350944019	9350944019	
20	Exit Pipe Assy	9364832005	—		527	Protection Net	9355444002	9355444002	
20	Exit Pipe	—	9364826004		582	Discharge Pipe-F	9301425017	—	
20	Discharge Pipe Assy	9368182007	9364826004		734	Cabinet Top Plate	9302937014	9302937014	
32-2	Control Box Metal-A	9355843003	9355843003		737	Entrance Pipe-A	—	9352384004	
34	Capacitor (Fan Motor)	9700468080	9700468080		744	Clamp (Condenser)	313166374106	313166374106	
37	Running Capacitor	9351208066	9351208066		745	Motor Support	313166036308	313166036308	
38	Capacitor Clamp Metal	313468061808	313468061808		764	Drain Cap	—	313166024302	
39	Propeller Fan Assy	9351589011	9351589011		765	Drain Pipe L-type	—	9301102000	
41	Motor Induction-OUT	9601113010	9601113010		766	Drain Pipe Packing	—	9301143003	
42	Motor Fixing Table	313166243804	313166243804		815	Terminal-3P	9355901024	—	
46	Compressor Assy	9364723006	9364723006		815	Terminal-4P	—	9358660041	
51	Special Nut M5 (For Comp.)	9359430018	9359430018		826	Condensing Pipe-B	—	9353015006	
55	Special Nut M8 (For Comp.)	9355091008	9355091008		982	Cord Clamp	9356857009	9356857009	
98	Fan Ring	313166296109	313166296109		982-2	Cord Clamp-B	9356858006	9356858006	
107	Rubber Seat-A (For Comp.)	9359425014	9359425014		987	Insulation Sheet	9358372005	9358372005	
109	Terminal Cover (For Comp.)	9364724003	9364724003						

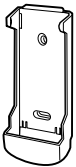
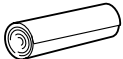
STANDARD ACCESSORIES

INDOOR UNIT ACCESSORIES

Name and Shape	Part No.	
	RSW-14CB	RSW-14HB
Wall hook bracket 	9304093008	9304093008
Wall cap 	313714296205	313714296205
Remote control unit 	9356765076 (AR-AB25)	9356765069 (AR-AB24)
Battery (penlight) 	0600185534	0600185534
Cable mark 	—————	9301385007
Tapping screw (big) (ϕ 4 x 20) 	301141164200	301141164200
Tapping screw (small) (ϕ 3 x 12) 	0700019036	0700019036
Flange screw (ϕ 4 x 10) 	9305114009	9305114009
Remote control unit holder case 	9305642014	9305642014
Cloth tape 	9308117007	9308117007
Seal-A 	9304536000	9304536000

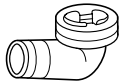
OUTDOOR UNIT ACCESSORIES

Name and Shape	Part No.	
	ROW-14CB	ROW-14HC
Hexagon wrench 	301980005800	301980005800
Drain pipe (Including drain packing) 	—————	9303029015
Drain cap 	—————	313166024302



MANUFACTURER :

Fuji Denki Sosetsu Co., Ltd.

Tokyo, Japan

February 2004 Printed in Japan



Большая библиотека технической документации

<https://splitsystema48.ru/instrukcii-po-ekspluatácii-kondicionerov.html>

каталоги, инструкции, сервисные мануалы, схемы.